



Simplified CO control panel

MCO



Automatic conventional COsensor control panel with carbon monoxide (CO) and nitrogen dioxide (NO₂) diffusion sensors

This control panel provides the MiniCO120 (Ref. MCO120) and MiniCO120DVB (Ref. MCO120DVB) references with 1 zone with 20 detectors capacity.

The model ending in "DVB" refers to the fact that it has double ventilation and batteries charger.

They are particularly suitable for parking or areas that need only 1 ventilation zone or installation of a few sensors in it.

The control panel displays the maximum concentration of CO in the detection zone, activating the ventilation and alarm when a specific concentration is reached after expiry of the set delay.

It has dry contact outputs for ventilation, an auxiliary 30Vdc output and an alarm dry contact output.

The system works with CO sensor ("SCO" reference) and NO₂ sensors ("SDN" reference) in the same area.

NO₂ sensors transform measures of NO₂ concentration in an equivalent measure of CO, and shown it in the display as a single concentration of CO, activating the ventilation and alarm when established CO levels are reached.

The control panel allows manual activation and deactivation of ventilation.

The equipment is designed for using diffusion sensors calibrated at factory for operation throughout the useful life of their sensors, and UNE 23300 certified.

Features:

- Control panel of 1 ventilation zone with diffusion sensor brand COsensor model SCO (CO sensor) and SDN (NO₂ sensor).
- Dry contact output (COM / NA) for ventilation 1 and ventilation 2 (DVB model only).
- 30Vdc 0,5A output.
- Dry contact alarm output.
- Space for 2x12 Vdc 2 Ah batteries (DVB model only).
- Display 3-digit, 7-segment.
- Dimensions: 248 x 240 x 115 mm.
- UNE 23300 certified.

TECHNICAL FEATURES			
Power supply	110/230Vac 50/60Hz	30Vdc intensity alarm output	0,5A
Maximum consumption	20VA at 230V/AC	30Vdc output fuse	Resettable
Batteries (only DVB model)	2 x 12V 2Ah SLA	Zone output voltage	26Vdc
Power supply fuse	4A	Zone fuse	2A
Battery charger	350mA 27V/DC 20°C	Dry contact fault	30Vdc 1A
Sensors by zone	20 CO / NO ₂	Dry contact alarm	30Vdc 1A
	(MCO120 / MCO120DVB)	Environmental conditions	-10°C +50°C
IP protection	IP30	Dimensions	248 x 240 x 115mm
Dry contact ventilation	230Vac / 30Vdc 1A	Weight (without batteries)	2kg
		Standard	UNE 23300

MiniCO120

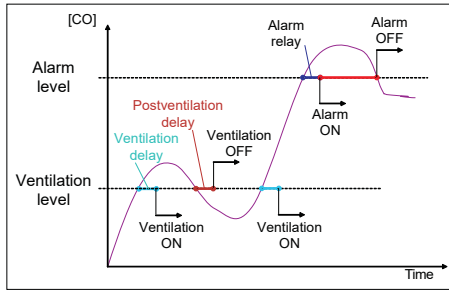

MiniCO120DVB

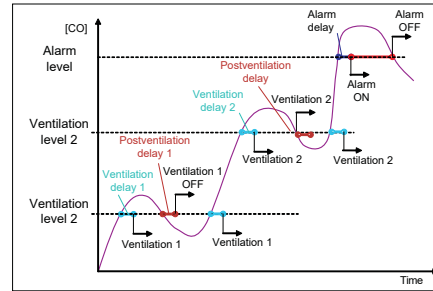

Parameter	Value	Range
Ventilation level	50 ppm	10 ÷ 290 ppm
Ventilation delay	4 min	1 ÷ 10 min
Ventilation OFF delay	4 min	Fixed
Alarm level	200 ppm	20 ÷ 30 ppm
Alarm delay	1 min	1 ÷ 10 min
Alarm OFF delay	1 min	Fixed

Parameter	Value	Range
Ventilation level 1	50 ppm	10 ÷ 280 ppm
Ventilation delay 1	4 min	1 ÷ 10 min
Ventilation OFF delay 1	4 min	Fixed
Ventilation level 2	100 ppm	20 ÷ 290 ppm
Ventilation delay 2	4 min	1 ÷ 10 min
Ventilation OFF delay 2	4 min	Fixed
Alarm level	200 ppm	30 ÷ 300 ppm
Alarm delay	1 min	1 ÷ 10 min
Alarm OFF delay	1 min	Fixed

Scheme of operation for control panels with ventilation

NOTE: Increments of time in minutes and concentration of toxic gases in 10 ppm

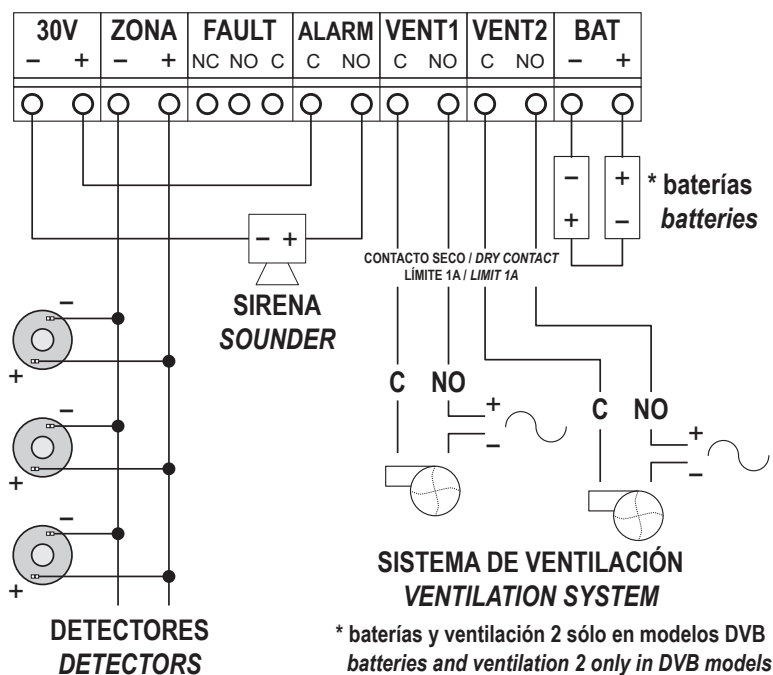

Wiring diagram